



**DESIGNING THE ARCHITECTURE OF POPULATION ADMINISTRATION
INFORMATION SYSTEMS USING METHODS RATIONAL UNIFIED
PROCESS (RUP)**

Mario Joseph Christianto¹, Djajasukma Tjahjadi², Christina Juliane³

Sekolah Tinggi Manajemen Informatika dan Komputer LIKMI, Indonesia^{1 dan 2}

STMIK AMIK Bandung, Indonesia³

Email: santosomario5@gmail.com¹, djaja@likmi.ac.id², christina.juliane@gmail.com³

Abstrak

Diterima: 26 Januari 2022
Direvisi: 14 Februari 2022
Disetujui: 15 Februari 2022

Penelitian ini bertujuan untuk mengetahui dan menganalisa bagaimana proses pelayanan administrasi yang berlangsung di Kecamatan Bojongloa Kaler, serta kelebihan dan kelemahan dari proses pelaksanaan yang berlangsung di sana. Kecamatan Bojongloa Kaler merupakan salah satu kecamatan yang berada di Kota Bandung, dan merupakan kecamatan yang paling padat penduduknya. Terdiri dari 5 kelurahan yaitu Kelurahan Jamika, Kelurahan Babakan Asih, Kelurahan Babakan Tarogong, Kelurahan Suka Asih, dan Kelurahan Kopo. Meskipun merupakan kecamatan yang paling padat penduduknya, nyatanya banyak permasalahan yang terjadi dalam proses pengelolaan administrasi di kecamatan ini. Berdasarkan kondisi tersebut maka akan dibuat suatu perancangan arsitek terkait dengan sistem informasi administrasi kependudukan di Kecamatan Bojongloa Kaler Kota Bandung. Metode yang digunakan dalam pembuatan arsitektur Sistem Informasi Administrasi Kependudukan di Kecamatan Bojongloa Kaler adalah metode *Rational Unified Process* (RUP). Dalam penelitian ini, metode penelilitan yang digunakan berasal dari 2 jenis sumber data, yaitu jenis data primer yang bersumber dari wawancara dan observasi dan jenis data sekunder, sedangkan hasil yang dibuat adalah implementasi dari metode *Inception* dan *Elaboration* dimana metode *Inception* meliputi beberapa proses seperti pemodelan proses pelayanan administrasi, analisis kebutuhan, penentuan tipe pengguna, dan peran pengguna, sedangkan metode *Elaboration* difokuskan pada pembuatan requirement tambahan dari *Inception* ditambah dengan analysis and design yang terdiri dari perbaikan *Use Case Diagram*, *Class Diagram*, *Activity Diagram*, dan *Sequence Diagram*. Pada akhirnya, dengan dibuatnya arsitektur Sistem Informasi ini, diharapkan petugas di Kantor Kelurahan Bojongloa Kaler memiliki gambaran sistem seperti apa yang diinginkan, sehingga dapat memperoleh rekomendasi tentang sistem tersebut dan pada akhirnya dapat membuat pelayanan administrasi dan kependudukan. Proses di Kecamatan Bojongloa Kaler lebih cepat, efektif, dan efisien.

Kata Kunci: *Rational Unified Process (RUP), Administrasi Kependudukan, Arsitektur Sistem Informasi*

Abstract

This study aims to determine and analyze how the administrative service process that takes place in the District of Bojongloa Kaler, as well as the advantages and disadvantages of the implementation process that takes place there. Bojongloa Kaler sub-district is one of the sub-districts in the city of Bandung, and is the most densely populated sub-district. It consists of 5 sub-districts, namely Jamika Village, Babakan Asih Village, Babakan Tarogong Village, Suka Asih Village, and Kopo Village. Although it is the most densely populated sub-district, in fact many problems occur in the administrative management process in this sub-district. Based on these conditions, an architect design will be made related to the population administration information system in Bojongloa Kaler District, Bandung City. The method used in making the Population Administration Information System architecture in the District of Bojongloa Kaler is the Rational Unified Process (RUP) method. In this study, the research method used comes from 2 types of data sources, namely primary data types sourced from interviews and observations and secondary data types, while the results made

are the implementation of the Inception and Elaboration methods where the Inception method includes several processes such as process modeling, administrative services, needs analysis, determining user types, and user roles, while the Elaboration method is focused on making additional requirements from Inception coupled with analysis and design consisting of improvements to Use Case Diagrams, Class Diagrams, Activity Diagrams, and Sequence Diagrams. In the end, with the creation of this Information System architecture, it is hoped that the officers at the Bojongloa Kaler Sub-district Office will have a picture of what kind of system they want, so they can get recommendations about the system and in the end can create administrative and population services. the process in the District of Bojongloa Kaler is faster, more effective, and efficient.

Keywords : Rational Unified Process (RUP), Population Administration, Information System Architecture

INTRODUCTION

Background

One of the reform agenda that will be continuously implemented by the Indonesian nation is to realize good governance or known as good governance, where one of the characteristics is a government that provides excellent service to the community. The services carried out by the government in this regard cover all aspects of people's lives, especially in the field of population.

Bojongloa Kaler district is one of the sub-districts in Bandung City, and is the most populous sub district. 2018 data shows the population of Bojongloa Kaler District is 122,137 people with an area of 3,063 square kilometers, and is located at an altitude of 696-713 meters above sea level and consists of 47 RW and 396 RT and 5 villages namely Kopo Village, Suka Asih Village, Babakan Tarogong Village, Babakan Asih Village, and Jamika Village.

Despite being the most populous sub-district in Bandung, there are some problems that are often encountered in administrative services. First, although there is already a centralized website in <https://multisite.bandung.go.id/kecamatan-bojongloa-kaler/>, this website has not provided a complete and specific picture, especially with regard to population data in Bojongloa Kaler District and the 5 villages that take shelter in it. Second, the administrative management process in Bojongloa Kaler District is still dominant using manual processes, where residents must come directly to the Bojongloa Kaler District office to conduct administrative management and bring the required requirements file for administrative services. Obviously this condition is very ineffective, especially in conditions where the community needs fast and appropriate services for the administrative service process it needs. Third, because most of the data still uses manual processes, there is the potential for errors and data discrepancies between Bojongloa Kaler District and the 5 villages that overshadow it, or in other conditions of administrative type data between different officers.

From these problems, the author plans to create "Architectural Design of Population Administration Information System Using Rational Unified Process (RUP) Method with Case Study of Bojongloa Kaler Sub-district Office, Bandung City. The RUP method was taken by the author because it is expected to increase the productivity of Bojongloa Kaler Subdistrict employees in the process of population administration services to the community in Bojongloa Kaler Subdistrict, Bandung City, so that it can produce faster, effective, and efficient services.

As a matter of consideration, there are several previous studies related to this research. First [Perwitasari](#), Afwani, & Anjarwani, (2020) about the application of RUP in the development of medical check-ups. In the research, RUP has an important role in the development of systems that can be adjusted to the changes made by clients. By using RUP, the process that is made can still be changed before the final stage. The final results of each stage of testing the RUP method plus blackbox testing, questionnaires, and usability were obtained results of 86.12% and very feasible. Next is the research conducted by [Tamami](#), Mursityo, & Pradana (2019), where the research presents the application of RUP in the development of merchandise sales information system. With the RUP method, it was found that the system developed can run well in some browser environments used, so it can be concluded that the RUP method is very adaptive and can be used in any browser. Finally, research conducted by [Ambika](#) & Supriya (2018) shows that RUP has an important role because from the results of the tests

conducted, the RUP method is easily implemented in the development of the system and the approach it uses can help the tasks and responsibilities of the organization. From the three journals, it can be concluded that the RUP method can be used because it provides various positive benefits, such as helping to adjust to various changes needed by the client and allowing several changes before the last stage, the development of systems made by the RUP method can be adaptive and used in various types of browsers. , and assist the tasks and responsibilities of the organization, as well as the most important thing is to increase the effectiveness and efficiency of the processes that take place. For the population information system, there are also several things to consider for this research. First, [Setiawan](#) & Suhaeliyah (2016) regarding the Design of Population Documentation Information System in Jatiwaringin Village, which started from population data collection still using manual books, then with the system, the population data management process can be simpler and make services to the community continue to improve. Second, [Setiawan](#) D. B., (2016) regarding the Design of Population Information System Applications in Gondomanan District, where in fact this system already has population data but is still manual. Making the system running well but still limited. Third, Kusumawati, [Pudjiantoro](#), & Nursantika (2017) regarding the Population Information System in Kandungora District, Garut Regency, where this system started from problems with administrative processes and population data that were still not tidy. With the Waterfall method, residents can be helped in the administrative process and find out the latest conditions related to population development in Kadungora District. Next, the fourth one is [Padlullah](#), Irfan Akbar, & Wiriasto (2017) regarding the Information System for Population Data Collection and Village Administration in Wanasaba Lauk Village, East Lombok Regency. At first, the population data collection and administration process was still incomplete and manual, using the Codenighter framework, the system could be accessed online and offline. Thus, the administrative process can run better and structured Fifth, [Dilapanga](#), Mantiri, & Mongi (2019) regarding Evaluation of Population Administration Information System Management at the Civil Registration Office, Tomohon City, North Sulawesi. Using analysis using Family Card, KTP, and birth data, and population mortality data for the 2016-2018 period, this system is effective but has a weakness, namely that the evaluation has not been carried out thoroughly. Sixth, [Rosdiana](#), Padeli, Sri Handayani, & Alfian (2019) regarding the design and development of a population administration information system using the PIECES method in Kemiri Village. Initially, there was no integrated system, but by using PIECES and UML analysis, the system that was created could simplify the administrative process, but the weakness is that the file order is not neat so the process takes quite a long time. Seventh, [Aviono](#), Sadikin, & Irawan (2021) regarding the Population Administration System Design at the Tangkit Baru Village Office. Eighth, [Kusumastuti](#), Supriyono, Mindarti, & Wanto (2020) regarding the highlights related to the governance of administrative services in South Lampung Regency, where it was found that the governance process was not balanced, especially the constraints of human resources in mastering and understanding technology. Finally, the ninth one is [Nugraha](#) (2017) regarding the Population Information System in Bagolo Village, which initially often results in inaccurate data coupled with problems related to data correspondence. The PIECES method and client-server basis produce faster and more accurate services, as well as provide appropriate recommendations for services to surrounding residents.

The last part of the introduction also explains the novelty (differences between this study and previous studies)

1. The research was conducted at the Bojongloa Kaler District Office as a center for administrative services for the 5 sub-districts within it
2. The data used in this study are birth data, death, moving, and arriving data as

well as administrative services such as moving out certificates, heir certificates, residents moving letters, family cards, and electronic ID cards (E-KTP).

3. This research is focused on architectural design related to the Population Administration Information System
4. In several previous studies, it was not explained in full regarding the methodology used in the research he made. And even from the system that has been made, even though it has good results, at the same time there are still some shortcomings that need to be addressed in further research.
5. In several previous studies, the data used for testing were not fully described, unless there was a study that used 4 data such as birth, death, Family Card, and E-KTP data or administrative letter processing. While this research uses 9 data, namely data on births, deaths, transfers, and arrivals as well as certificates of moving out, certificates of heirs, letters of moving come residents, family cards, and electronic ID cards (E-KTP).
6. This research uses the RUP method in Bojongloa Kaler District, where in previous studies RUP was used in research related to hospital services, sales business, and learning media.

The purpose of this study is to design the architecture of the Population Administration Information System in Bojongloa Kaler Subdistrict, Bandung City based on the Rational Unified Process (RUP) method

Information System

[Irviani](#) & Anggraini (2017) defines information systems divided into Systems and Information. A system is defined as a collection of people who cooperate with the rules that are made systematically and structured with the aim of forming a unity in carrying out a function to achieve a goal, while information is defined as data that is processed into something more meaningful and useful for the person who receives it, as well as a component used to reduce uncertain situations in the decision-making process about a condition. Overall, an information system is a structured combination of human, hardware, software, networking, data resources that collect, transform, and develop information sets within an organization. Meanwhile Hidayat, (2019) defines Information Systems as a tool that aims to process data into sources of information used as a decision-making step, can also be defined as a medium of sharing and disseminating information to users appropriately and appropriately. At least, there are three main components, namely data collection and entry, data storage and retrieval, and application of data. In addition, there are at least 4 basic concepts in information systems, namely:

1. *Input*: involves the collection of raw data from within an organization or external environment for the processing of data in an information system.
2. *Process*: involves the process of converting raw inputted data into better form
3. *Output*: the transfer of information processes to people or groups that need them or to an activity taking place
4. *Feedback*: the *output* is returned to the relevant members of the organization to then help evaluate and correct the input stages that have been done

Rational Unified Process

[Prabowo](#) (2020) defines *rational unified process* (RUP) as a framework related to the *software* development process in an iterative manner. The RUP was first created by Rational Software (a division of IBM) since 2003, and is also known as the Integrated

Process model. RUP can increase team productivity to provide opportunities for each member to be able to access practically based on guidance, templates, and guidance tools for crucial processes in development activities. In addition, RUP is also one of the recurring software development models that provide tasks and responsibilities within the organization to ensure how the software production process is of high quality, as a support and answer the needs of users with schedule estimates and rules that are prepared in advance. [Basri, Mahmood, & Kama \(2020\)](#) also defines *rational unified process* (RUP) as a use-case driven model designed with regard to matters related to requirements related to the process of developing object-oriented software. Still according to [Prabowo, \(2020\)](#), there are four phases in the RUP, namely:

1. Inception: the initial stage identifies the system to be developed. This initial phase is required to be able to interact with customers, as a first step to identify the needs of the system to be created. This step is important so that software developers have a common understanding between the systems to be created with the needs of users.
2. Elaboration: the stage to carry out the complete design process based on the results of analysis that has been done at the inception stage. It has not yet entered the software creation stage directly, but it is focused on stabilizing the concept of reviewing the predefined planning.
3. Construction: the stage of lending the results of the design and testing the results of the implementation that has been made.
4. Transition: the final product final stage that has been completed, where it is necessary to analyze whether the software created is in accordance with the needs of the desired user or there are errors that need to be corrected. This last phase is also related to the installation and rollout process.

Ultimately, although the RUP describes an iterative and incremental approach to application development, it is not an agile approach but contains strong guidelines on when and how to do the job. Over time, more and more details were added to the RUP, including descriptions of how to support the process. The final version 7.0 was published in 2005, and today the RUP is still quite popular but no longer supported by Rational or IBM as its ralent company (Kneuper, 2018)

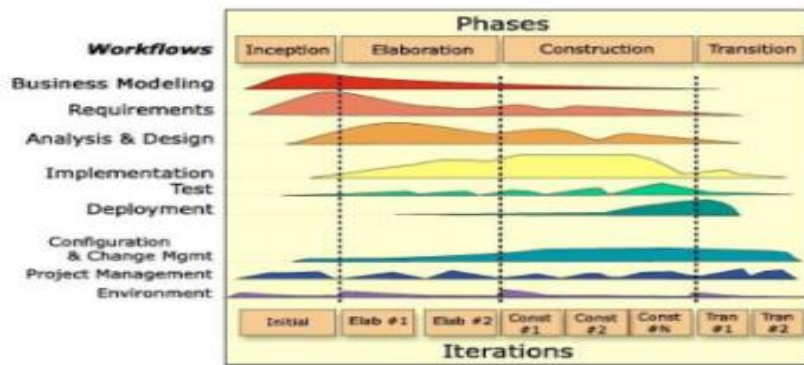

Figure 1. Metode RUP
Sumber : (Prabowo, 2020)

Object Based Design

[Mulyana, Putra, & Suriansyah \(2019\)](#) explained that Object-Based Design is widely used in systems that use a complex iterative approach, and that means that software is organized by humans as a collection of objects that have a certain data structure. [Siahaan \(2020\)](#) also defines Object Oriented Design as a process of modeling applications in a similar way using the human point of view in defining real objects. Usually this is a relationship between classes, where there are some objects from a particular class have similar exclusive characteristics. [Ginantra, et al., \(2020\)](#) explain that Object-Based Design is actually inspired by the complex problems that occur in the real world, where the

modeling created to design it is the design of object-oriented models. There are at least five components used in object-oriented modeling:

1. Object
2. Attributes: object properties
3. Class: object blueprint, printed by class so that objects originating from one class have the same structure and methods
4. Classes that can be organized by hierarchical form
5. Inheritance

From this, [Habibi](#) & Aprilian, (2020) defines UML as object-oriented visual modeling used as a standard visualization, design, and documenting of software systems, and becomes the standard blue-print software writing.

Use Case Diagram

[Habibi](#) & Aprilian (2020) defines the Use Case Diagram as an UML diagram model used to describe the functional needs a system needs, as well as a concise depiction diagram of who its users are and what can be done. The function of Use Case Diagram is to briefly describe who is using the system and what it can do. Through this diagram, it can be known what functions are contained in the system and how it works, namely describing the type of relationship between the user of the system and the system itself through a flow that is affiliated with the workings of the system. Use Case Diagram is also an overview of the effects of system functionality, and the following is explained how to describe it:

- a. The use case diagram is a modeling to describe the behavior of the system to be created.
- b. The use case diagram also describes the interaction between one or more actors and the system to be created.
- c. The use case diagram is used to find out what functions are in the system and who has the right to use it. The focus emphasized is "what" the system does, not "how"
- d. A Use Case represents the interaction between the actor and the system.
- e. Use Case describes simply the function of the system from the user's angle

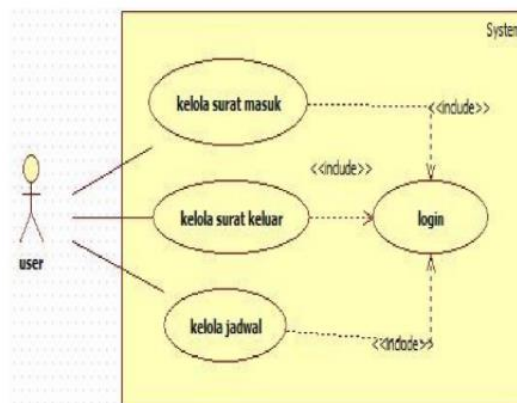

Figure 2 : Use Case Diagram

Source: (Habibi & Aprilian, 2020)

Class Diagram

[Habibi](#) & Aprilian (2020) defines a class diagram as a class and its correlations in the system, and is depicted with a box divided into 3 parts. The top is the class name, the middle section contains the class variables, and the bottom contains the method of the class. Class Diagram is the most useful type of diagram because it can clearly map the structure of a particular system by modeling classes, attributes, operations, and relationships between objects. In addition, [Aprilian](#) & Saputra (2020) it also defines a class

diagram as a static diagram that describes the structure of a system by showing classes, systems, attributes, operations, and relationships between objects.

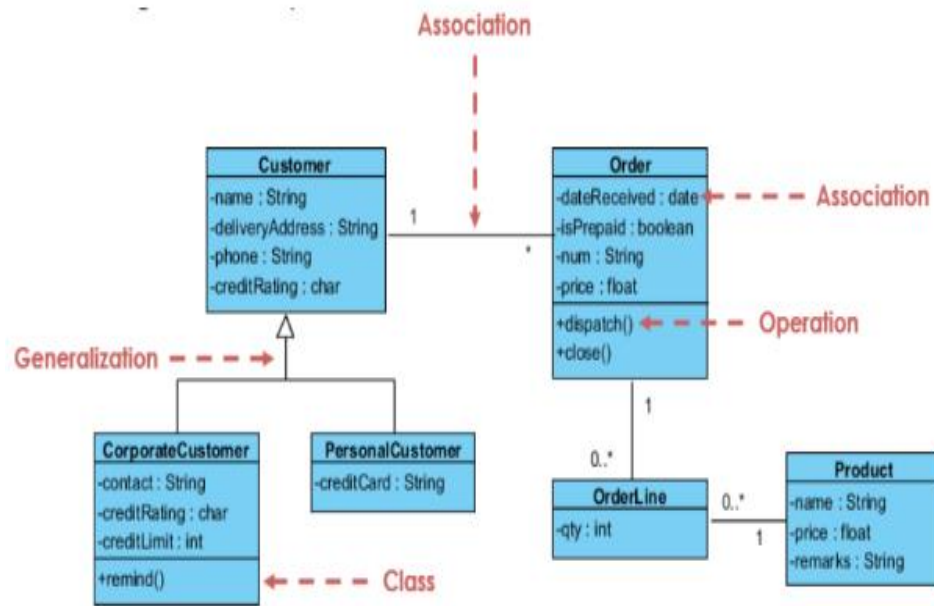

Figure 3. Contoh Class Diagram
Sumber : (Aprilian & Saputra, 2020)

There are three notations, namely

1. Class Name: The class name appears on the first partition
2. Class Attributes
 - a. Attributes are placed in the second partition
 - b. Attribute type displayed after point two
 - c. Associate a map to a member variable in a code
3. Class Operations
 - a. The operation is displayed in the third partition
 - b. The type of method return is displayed after the two-point at the end of the method signature
 - c. The operation maps the class method in code.

Activity Diagram

[Suryansah](#) & Habibi (2020) defines activity diagrams as techniques for describing procedural logic. Its role has similarities with flowcharts, but the way to distinguish the two is that diagram activities support parallel behavior whereas flowcharts do not. At least, there are 8 components involved in the activity diagram, namely:

1. Activity or State: Indicates the activity performed
2. Initial Activity: Indicates the beginning of the activity started
3. Final Activity: Indicates the end of the activity
4. Decision: Describes a condition test to ensure control flow flows over more than one track
5. Merge: combines flows broken down by decision
6. Synchronization: consists of fork and join
7. Swim lanes: Breaks down activity diagrams into rows and columns to divide the responsibilities of objects performing an activity
8. Transition: indicates the next activity after the previous activity

Sequence Diagram

[Rusmawan](#) (2019) a sequence diagram as an interaction diagram arranged in a time order,

in which each diagram presents one flow from multiple flows in a use case, and can also be defined as an interaction diagram to explain the execution of semantic scenarios in describing relationships between objects in a given time sequence. Sequence diagrams are designed based on activity diagrams and group diagrams, and describe the flow of messages that occur between classes in class diagrams using their operations.

Population

[Bidarti](#) (2020) defines population as a science that studies the dynamics of human life, which includes size, standards, population distribution, and changes in population numbers as a result of birth, death, migration, and aging. In this case, population analysis can sulk at society as a whole or groups according to certain exclusive criteria and components such as education, religion, or other things. Population is also related to the number, structure, age, gender, religion, birth, marriage, pregnancy, death, distribution, mobility, quality and resilience of politics, economy, social, and culture.

Data Administration and Population Data

[Tambunan](#) (2019) and Sumadiono (2018) define population administration under Law No. 23 of 2006, as a series of structuring and regulating activities in the process of ordering documents and population data through the process of population registration, civil registration, management of population administration information systems, and utilization of results for public service processes and other sector development. Documents and population data owned by residents such as KTP and KK, have four important purposes, namely, provide clarity of identity and status for the owner, Provide legal clarity, Provide legal protection and comfort for the owner, and Provide benefits for the interests of administration and other public services.

Good Governance

[Hamirul](#) & Alamsyahril (2020) Defines good governance as the implementation of solid and responsible development management, which is in line with the principles of democracy and market efficiency. Good governance is a concept that refers to the process of making decisions and their implementation that refers to the process of making decisions and implementing them that can be accounted for. At the very least, there are some principles of good governance, namely, Community Participation, Enforcement of the Rule of Law, Transparency, Concern for Stakeholders/ Business World, Consensus-oriented, Equality, Effectiveness and Efficiency, Accountability, and Strategic Vision

In addition, according to [Waluyo](#), (2019), *good governance* and UNDP is a government that spreads synergistic and constructive relationships between the state, private sector, and society. Meanwhile, the World Bank formulates good governance as a solid and responsible development management implementation activity. Also the Association of Regency Governments throughout Indonesia (APKASI) mentions at least 10 general principles of good governance, namely Participation, Rule Enforcement, Transparency, Equality, Responsiveness, Insight, Accountability, Supervision, Efficacy & Effectiveness, and Professionalism. In addition to these principles, there are also three pillars involved, namely the state, private, and the role of civil society.

RESEARCH METHODOLOGY

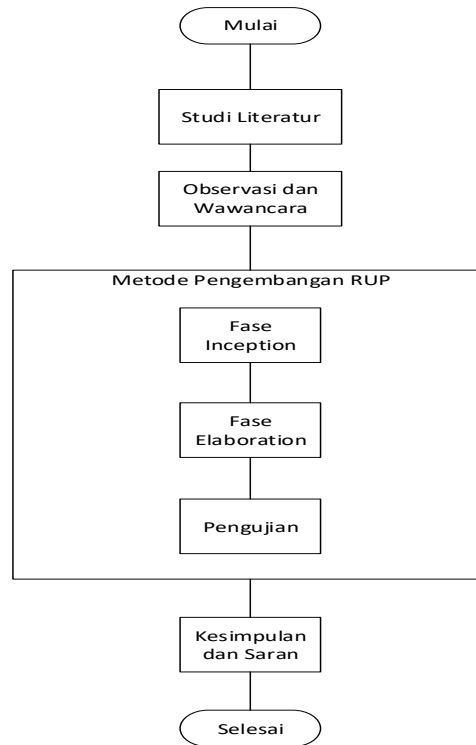

Figure 1 : Research Methodology *Flowchart*

Based on Figure 7, it is necessary to know in advance that in the RUP there are actually 4 phases, namely Inception, Elaboration, Construction, and Transition, but in this study, only 2 initial phases, namely Inception and Elaboration, will be used, plus testing. Here's a little explanation of these steps:

1. Literature Study: studying various literatures from related sources related to research.
2. Observations and Interviews: conducted direct observations at the Bojongloa Kaler District Office, Jl. KH Wahid Hasyim No. 258, and conducted interviews with the sub-district head. Bojongloa Kaler or other related officials.
3. RUP Development Method
 - (a) Inception: studying data related to the results of observations and interviews, making modeling of ongoing administrative service processes, then also analyzing needs, user types, user roles, and modeling user behavior and relationships
 - (b) Elaboration: system design in the form of use case diagrams, activity diagrams, class diagrams, sequence diagrams.
 - (c) Testing: the results of the Inception and Elaboration phases were tested to see whether the process was as needed. The goal is to find out the strengths and weaknesses of the design that has been made.
4. Making Reports, Conclusions, and Suggestions

All steps of this research were carried out in the time period August-December 2021

RESULTS AND DISCUSSION

Inception Phase

System Existing Condition

Discusses the description of the current condition of the existing system, where it is necessary to know that the ongoing system is still using a manual system which is still

recorded in a book or a special file available. Figure 8 shows the existing process of the system

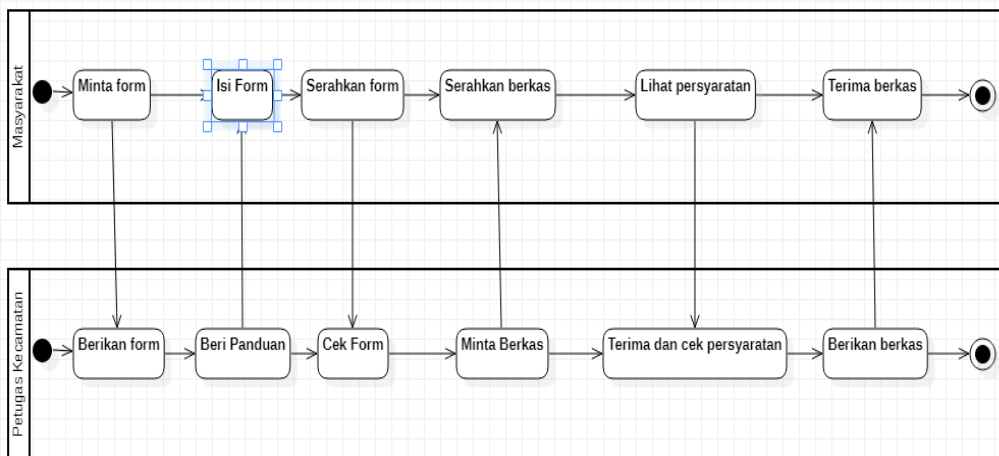

Figure 2 : Model Existing System

Problem Analysis

Problem analysis was made using the SWOT tool. Shown by table 1 below:

Table 1. SWOT Analysis

Strength	Weakness
1. Bojongloa Kaler District has good service facilities	1. The service process, most of which still use manual systems, requires a long time for verification and validation
2. Bojongloa Kaler District has competent human resources in administrative services	2. The data processing process is still not optimal
Opportunity	Ancaman
1. The development of extensive and easily accessible information technology	1. Because it is still done manually, there is the potential for errors to be encountered.
2. There is trust from the people of Bojongloa Kaler District regarding the administrative service process	

Identification of System Description and Actors to be involved

The purpose is to find out what kind of system will be formed and who will be involved in it. In this case the actors involved are the Community and Officers. Shown by table 2 below:

Table 1. Systems and Actors Identification

System Description:		
This Population Administration Information System was created in an effort to create faster, more effective, and efficient services for the people in the Bojongloa Kaler sub-district and the 5 sub-districts within it. With this system, it is hoped that the administrative service process in Bojongloa Kaler District can be more organized, both in terms of administrative services and in terms of reporting. This system serves administrative services and population recapitulation, and will be equipped with file uploads of requirements and tables of administrative service schedules for the community. This system is expected to reduce the potential for crowded queues that usually occur when the process is done manually at the Bojongloa Kaler District Office.		
Identification of Systems and Actors		
No	Menu	Actor
1	Daftar	Masyarakat dan Petugas
2	Edit Data	Masyarakat dan Petugas
3	Form Administrasi	Masyarakat
4	Upload File	Masyarakat
5	Upload Berkas	Masyarkat

6	Cek Upload File	Petugas
7	Cek Upload Berkas	Petugas
8	Data Administrasi	Petugas
9	Rekapitulasi Kependudukan	Petugas
10	Riwayat Administrasi	Masyarakat dan Petugas

Elaboration Phrase

Identification of Functional and Non-Functional Needs

The purpose of this process is to find out an overview of the processes that will run on the system or application that is compiled. Explanations related to functional and non-functional requirements will be explained in table 3 and table 4 below:

Table 2. System Functional Requirements

No	Deskripsi Sistem	Aktor
1	Pendaftaran untuk menjadi anggota	Masyarakat
2	Pengisian formulir sesuai jenis administrasi	Masyarakat
3	Melakukan perubahan data	Masyarakat
4	Upload berkas persyaratan terkait jenis administrasi	Masyarakat
5	Melihat jadwal pengurusan administrasi	Masyarakat
6	Mengelola data administrasi masyarakat (Melihat, Mengubah Menambah, Menghapus)	Petugas
7	Merekapitulasi dan mengelola data kependudukan baik itu data kelahiran, kematian, pindah, dan kematian (Melihat, Mengubah, Menambah, Menghapus)	Petugas
8	Mengecek formulir yang sudah diisi sesuai jenis administrasi	Petugas
9	Mengecek file yang sudah diupload, apakah sudah sesuai dengan persyaratan atau belum	Petugas
10	Mengelola riwayat pelayanan administrasi masyarakat (melihat, mengubah, menghapus)	Petugas

Table 3 : System Non-Functional Requirements

Jenis Kebutuhan Non-Fungsional	Requirement
<i>Hardware</i>	RAM : Minimal 4 GB Sistem Operasi Minimum : Windows 8
<i>Software</i>	Google Chrome, Microsoft Edge
Batasan Sistem	<ol style="list-style-type: none"> 1. Sistem bisa dijalankan di beberapa <i>web browser</i> seperti Google Chrome dan Microsoft Edge 2. Sistem harus memastikan bahwa data yang digunakan terlindung dari akses yang tidak berwenang 3. Besarnya file upload maksimal 20 MB 4. Sistem memiliki tampilan yang mudah dipahami oleh masyarakat dan petugas

Use Case Diagram

This creation aims to create an overall picture of the process that will be made on the system. Also made a complete specification of the use case made. Shown by figure 9, table 5, and table 6 below:

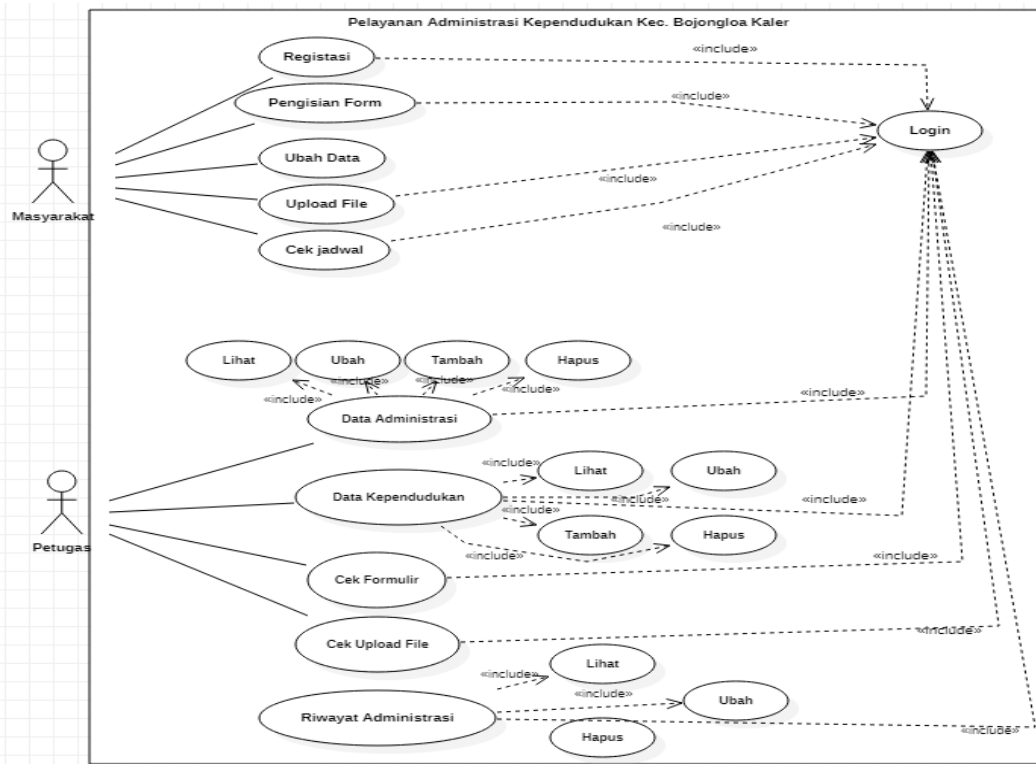

Figure 3 Overall Population Administration System Use Case

Table 4 : Specifications of Administrative Service Use Case

Fase	Informasi
Kode Use Case	UC-1
Kode Fitur	FTR-UC-1
<i>Brief Description</i>	Use Case ini dibuat untuk mendeskripsikan bagaimana proses pelayanan dan aktivitas administrasi di Kantor Kecamatan Bojongloa Kaler, Kota Bandung.
<i>Actor</i>	Masyarakat (Aktor1), Petugas (Aktor2)
<i>Pre-Conditions</i>	Aktor melakukan login dan masuk ke menu utama
<i>Basic Flows of Events</i>	<ol style="list-style-type: none"> 1. Use Case dimulai ketika aktor berada pada menu utama 2. Aktor1 masuk ke menu formulir 3. Aktor1 memilih jenis administrasi yang ingin dilakukannya 4. Sistem menampilkan formulir yang sesuai dengan jenis administrasi 5. Aktor1 mengisi formulir 6. Aktor1 mensubmit formulir yang dimaksud 7. Aktor2 mengecek formulir yang sudah diisi 8. Setelah sesuai, tampilkan menu upload berkas 9. Aktor1 mengupload file berkas 10. Aktor2 mengecek file berkas yang sudah diupload 11. Setelah sesuai, maka data administrasi akan masuk ke dalam sistem administrasi 12. Rekapitulasi kegiatan administrasi 13. Use Case selesai
<i>Post Conditions</i>	Sistem menampilkan berkas administrasi yang sudah diinput masyarakat sesuai jenis administrasi yang sebelumnya dipilih.

Table 5 : Recapitulation Use Case Specification

Fase	Informasi
Kode Use Case	UC-2
Kode Fitur	FTR-UC-2

Fase	Informasi
<i>Brief Description</i>	<i>Use Case</i> ini merupakan lanjutan dari sebelumnya. Tapi fokus lebih membahas ke petugas
<i>Actor</i>	Petugas (Aktor2)
<i>Pre-Conditions</i>	Aktor2 melakukan login dan masuk ke menu utama
<i>Basic Flows of Events</i>	<ol style="list-style-type: none"> 1. <i>Use Case</i> dimulai ketika Aktor2 berada pada menu utama 2. Aktor2 masuk ke menu rekapitulasi 3. Sistem memberikan pilihan, antara rekapitulasi kependudukan atau rekapitulasi administrasi 4. Aktor2 masuk ke menu rekapitulasi administrasi 5. Sistem menampilkan rekapitulasi administrasi yang dilakukan 6. Aktor2 mengecek dan mencocokkan dengan catatan data administrasi 7. Aktor2 melakukan perubahan, penambahan dan menghapus data administrasi jika ditemukan kekeliruan 8. Setelah sesuai, kemudian hasil rekapitulasi administrasi disubmit. 9. Sistem kembali ke menu utama 10. Aktor2 masuk ke menu rekapitulasi kependudukan 11. Sistem menampilkan data kependudukan (kelahiran, kematian, pindah, dan datang) dari 5 kelurahan di Kecamatan Bojongloa Kaler 12. Aktor2 melakukan pencocokan dengan data yang didapat. 13. Aktor2 melakukan perubahan, penambahan dan menghapus data kependudukan jika ditemukan kekeliruan 14. Setelah sesuai, maka hasil rekapitulasi kependudukan disubmit 15. <i>Use Case</i> selesai
<i>Post Conditions</i>	Sistem menampilkan hasil rekapitulasi dari data kependudukan 5 kelurahan di Kecamatan Bojongloa Kaler serta hasil administrasi yang berlangsung pada sistem sesuai penjelasan pada tabel sebelumnya.

Activity Diargam

In this section, 3 activity diagrams will be made related to administrative services from the community and officers side, as well as making population administration recapitulation. The following is shown by Figure 10, Figure 11, and Figure 12 below:

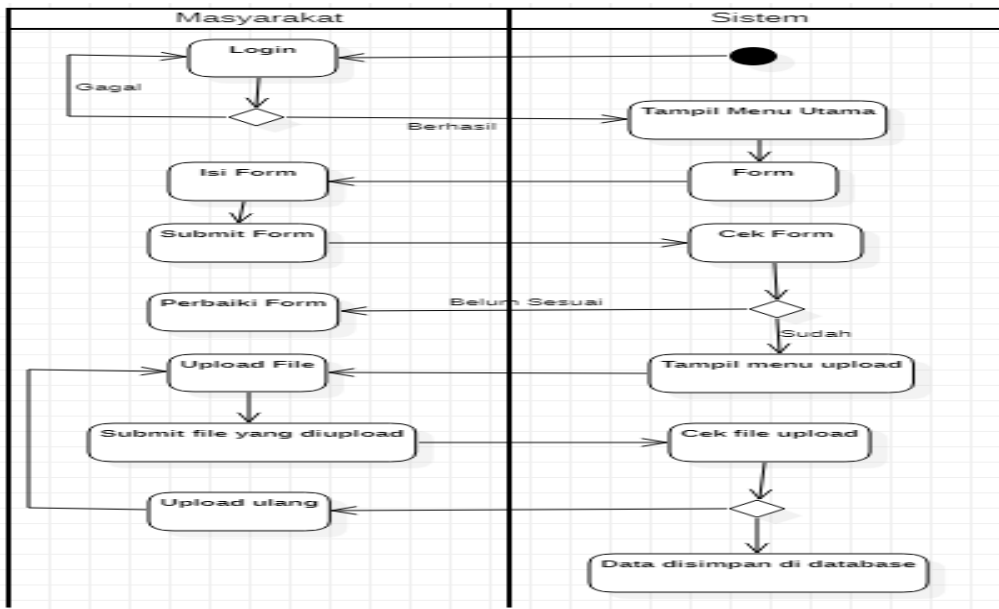

Figure 4 : Activity Diagram of Administrative Services (community side)

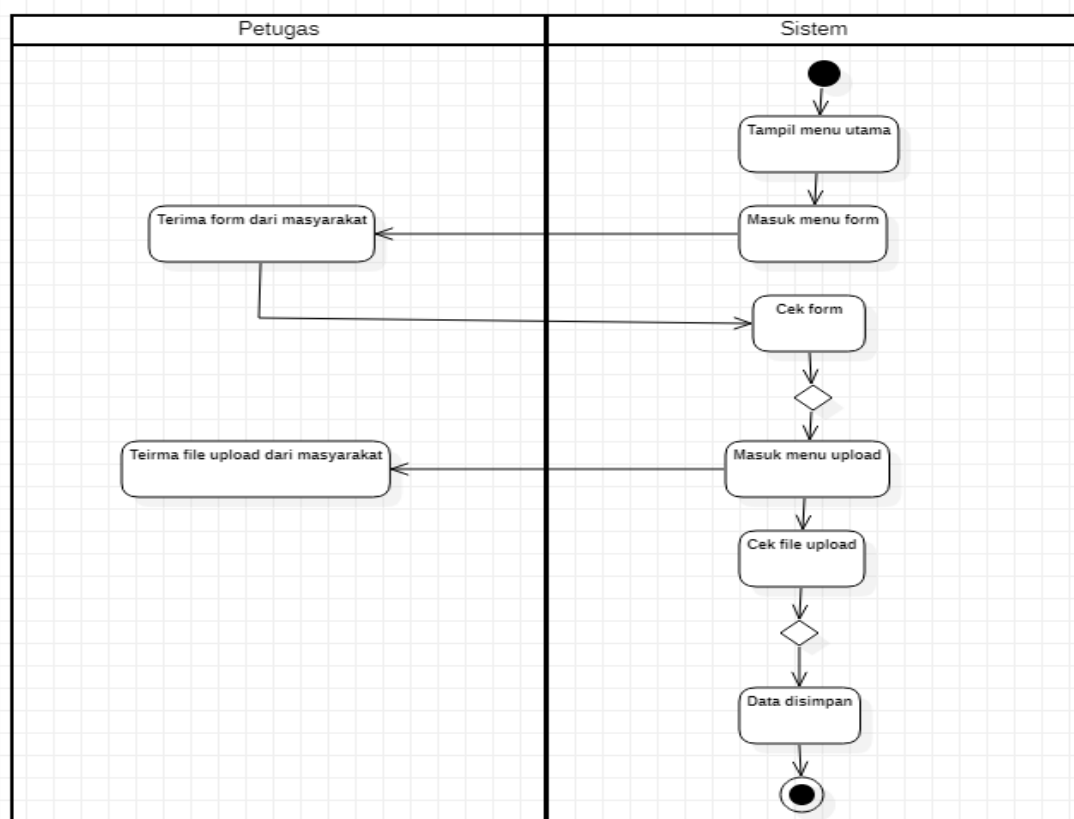

Figure 5 : Activity Diagram of Administrative Services (officer side)

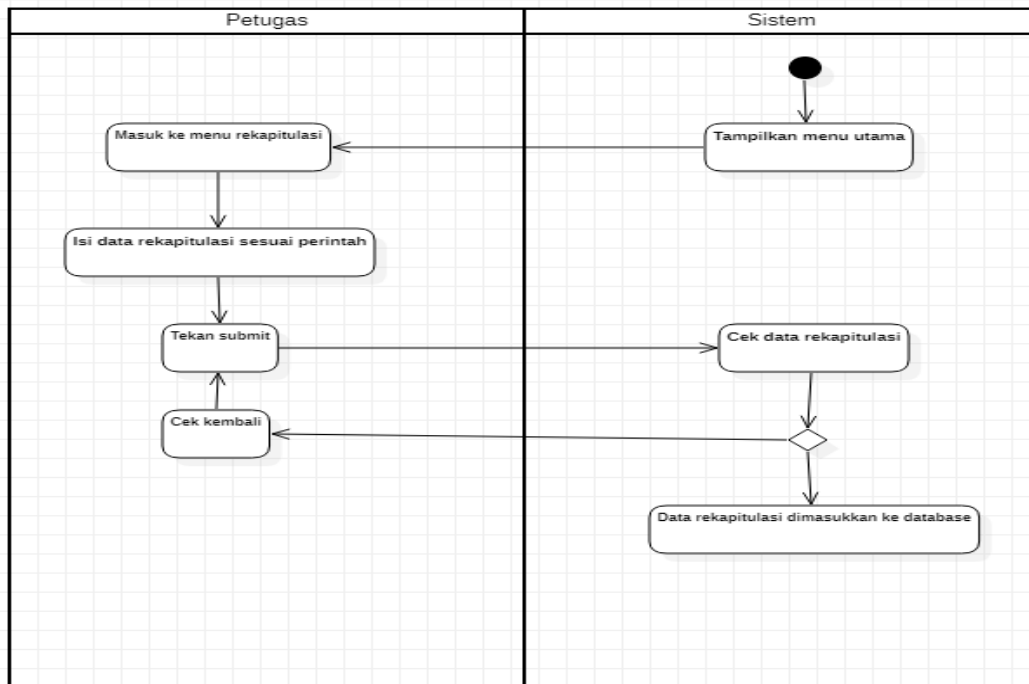

Figure 6 : Activity Diagram of the population and administration recapitulation process

Package Diagram

Package Diagrams are actually made with the aim of making grouping elements such as use cases or class diagrams. In this study, a package diagram will be made related to the flow of the administrative service process and the data recapitulation process. Shown by the following pictures 13 and 14:

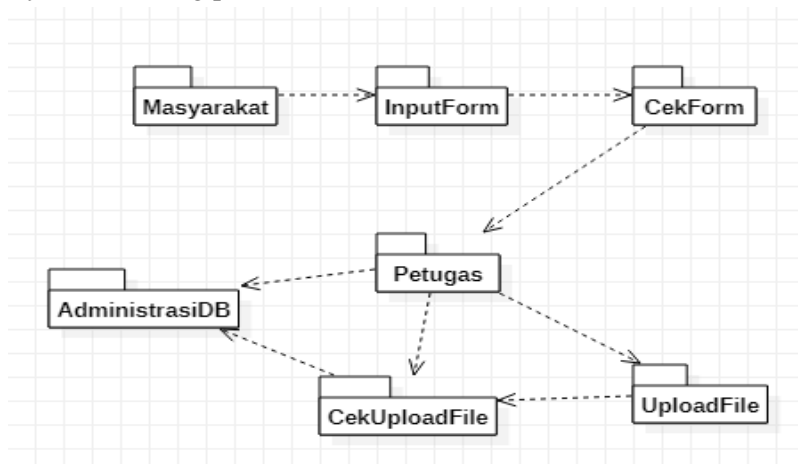

Figure 7 : Package Diagram of Administrative Services

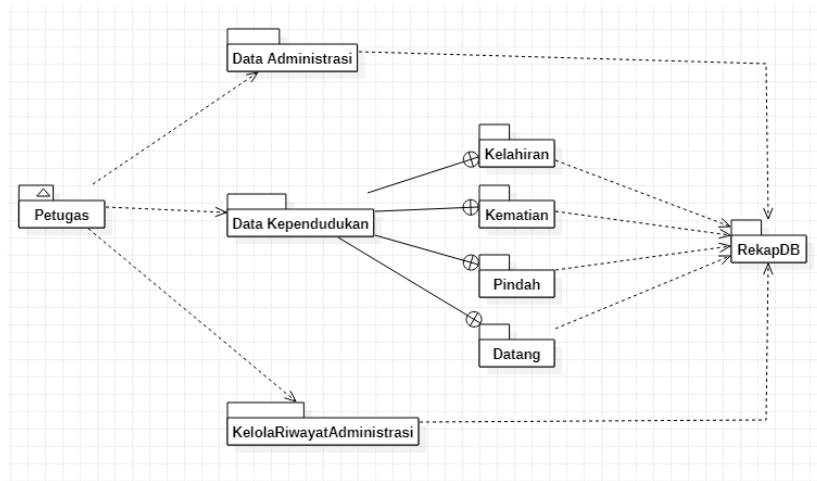

Figure 8 : Package Diagram of Population Recapitulation

Class Diagram

This class diagram is made by creating relationships between classes, using the Models Views Controllers (MVC) architectural model so that the design of the existing classes in the system, where the purpose of making it is to describe the relationships between classes in the architecture that is created. Shown by Figure 15 below:

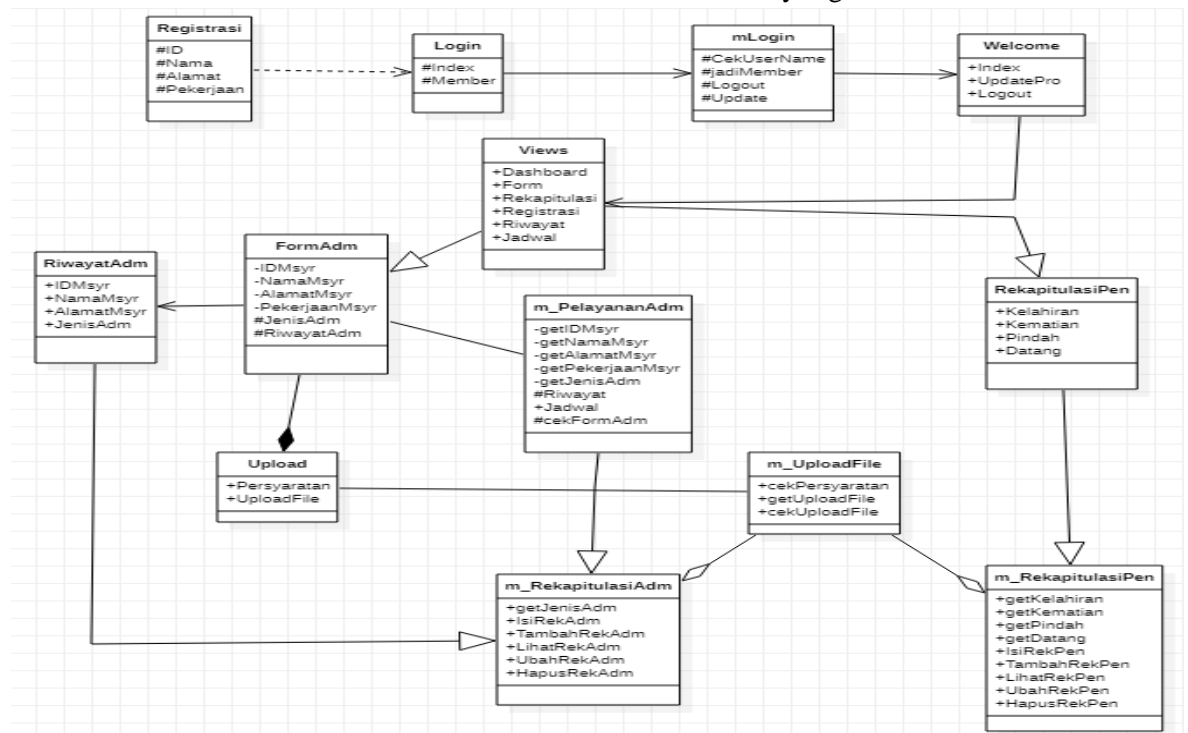

Figure 9 : Class Diagram

Sequence Diagram

Making this sequence diagram is divided into 2 parts. The first part deals with the ongoing administrative service process (figure 16), while the second part deals with the process of recording population and administrative data (figure 17).

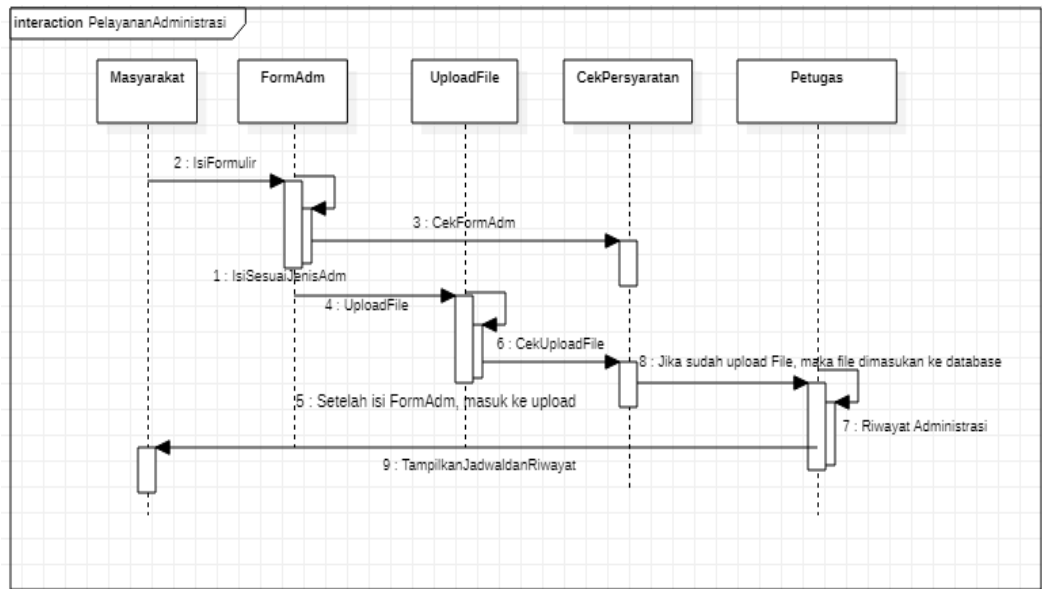

Figure 10 : Sequence Diagram of Administrative Service Process

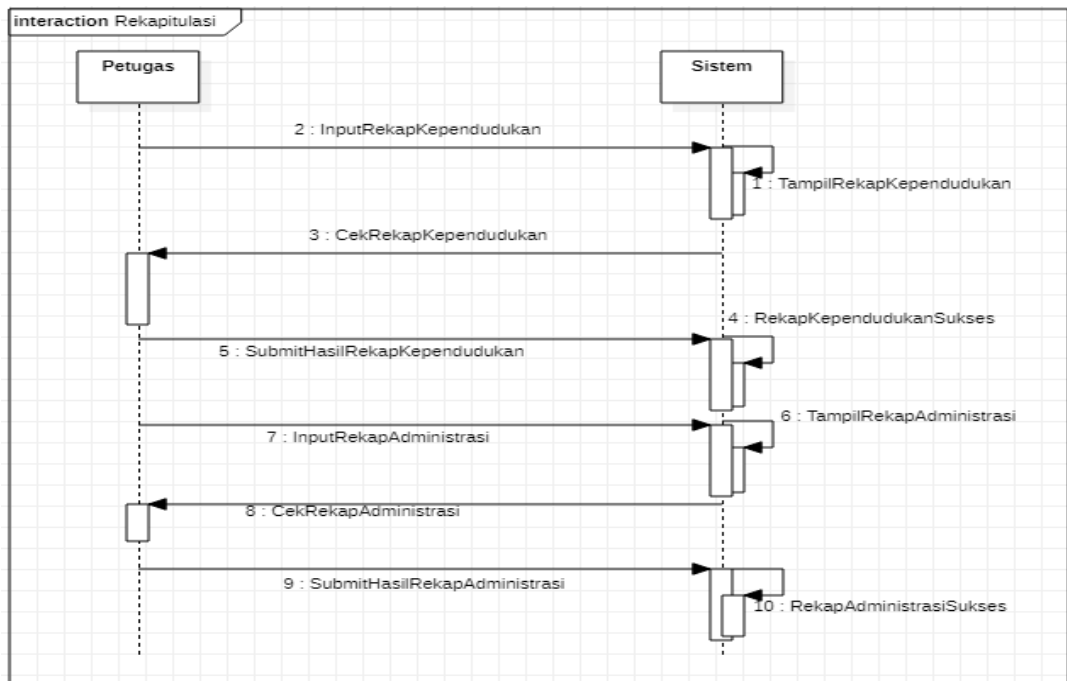

Figure 11 : Sequence Diagram of Population and Administration Recording Process

CONCLUSION

From the results, the researchers conclude that designing Population Administration Information System Architecture Using the Rational Unified Process (RUP) method with a case study of Bojongloa Kaler District, Bandung City aims to help accommodate the administrative service process that is faster and neatly organized, efficient, and effective

Architectural design is made using the RUP method, namely Inception and Elaboration. In Inception there are several processes, such as administrative service process modeling, needs analysis, determining user types and user roles, and the relationships between them, while Elaboration is focused on making additional requirements from the previous section plus analysis and design which consists of making Use Case Diagrams that are improved from previous stages, Class Diagrams, Activity Diagrams, and Sequence Diagrams.

REFERENCES

- Ambika, N., & Supriya, P. (2018). Detection of Vanilla Species by Employing Image Processing Approach. *8th International Conference on Advances in Computing and Communication*, 474-480.
- Aprilian, L. V., & Saputra, H. K. (2020). *Belajar Cepat Metode SAW*. Bandung: Kreatif Industri Nusantara.
- Aviono, D., Sadikin, A., & Irawan, B. (2021, Maret). PERANCANGAN SISTEM INFORMASI ADMINISTRASI KEPENDUDUKAN PADA KANTOR DESA TANGKIT BARU. *Jurnal Ilmiah Mahasiswa Sistem Informasi*, 15-26.
- Basri, S., Mahmood, Y., & Kama, M. (2020). *Software Requirement Change Effort Estimation*. India: Exceller Books.
- Bidarti, A. (2020). *Teori Kependudukan*. Penerbit Lindan Bestari.
- Dilapanga, A. R., Mantiri, J., & Mongi, C. (2019). Evaluation of the Management of Population Administration Information System at the Department of Population and Civil Registration of Tomohon City. *2nd International Conference on Social Science*, 383, 728-730.
- Ginantra, N. W., Wardani, N., Aristarny, I. A., Suryawan, I. D., Ardiana, D. Y., Sudipa, I. I., et al. (2020). *Basis Data : Teori dan Perancangan*. Yayasan Kita Menulis.
- Habibi, R., & Aprilian, R. (2020). *Tutorial dan penjelasan aplikasi e-office berbasis web menggunakan metode RAD*. Bandung: Kreatif Industri Nusantara.
- Hamirul, H., & Alamsyahril, A. (2020). *Good Governance Dalam Perspektif Kualitas Pelayanan Publik*. Malang: CV Pustaka Learning Center.
- Hidayat, F. (2019). *Konsep Dasar Sistem Informasi Kesehatan*. Yogyakarta: Penerbit Deepublish.
- Irviani, E., & Anggraini, R. (2017). *Pengantar Sistem Informasi*. Yogyakarta: Penerbit ANDI.
- Kneuper, R. (2018). *Software Processes and Life Cycle Models, an Introduction to Modelling, Using and Managing Agile, Plan-Driven and Hybrid Processes*. Darmstadt: Springer.
- Kusumastuti, H., Supriyono, B., Mindarti, L. I., & Wanto, A. H. (2020). "THE GOVERNMENT POLICY CAPACITY: IMPLEMENTATION OF POPULATION ADMINISTRATIVE SERVICES IN VILLAGE GOVERNMENT". *Psychology and Education Journal*, 4574-4584.
- Kusumawati, A., Pudjiantoro, T. H., & Nursantika, D. (2017). Sistem Informasi Kependudukan Pada Kecamatan Kadungora Kabupaten Garut. *Prosiding Seminar Nnaional Komputer dan Informatika*, 27-34.
- Mulyana, I., Putra, A. P., & Suriansyah, M. I. (2019). *Buku Ajar Desain Grafis dan Multimedia*. Bogor: Flash.
- Nugraha, U. (2017). Design of Information Systems for Population Data Collection Based on Client-Server at Bagolo Village. *AIP Conference Proceedings*, 1-9.
- Padlullah, Irfan Akbar, L. S., & Wiriasto, G. W. (2017). SISTEM INFORMASIPENDATAAN KEPENDUDUKAN DAN ADMINISTRASI DESA (STUDY KASUS PADA DESA WANASABA LAUK, KABUPATEN LOMBOK TIMUR). 1-10.

- Perwitasari, R., Afwani, R., & Anjarwani, S. E. (2020). *JTIKA*, Vol. 2, No. 1, Maret 2020. *PENERAPAN METODE RATIONAL UNIFIED PROCESS(RUP) DALAM PENGEMBANGAN SISTEM INFORMASI MEDICAL CHECK UP PADA CITRA MEDICAL CENTRE(The Application of RationalUnifiedProcess (RUP) in Development of a Medical CheckUpInformation System at Citra Medical Centre, 76-88.*
- Prabowo, M. (2020). *Metodologi Pengembangan Sistem Informasi*. Salatiga: LP2M IAIN Salatiga.
- Rosdiana, R., Padeli, P., Sri Handayani, R. S., & Alfian, R. (2019, September). Design And Development of Population Service Administration System With Pieces Method In Kemiri Village Head Office Banten. *ADI Journal on Recent Innovation (AJRI)*, 1, 34-48.
- Rusmawan, U. (2019). *Teknik Penulisan Tugas Akhir dan Skripsi Pemrograman*. Jakarta: Elex Media Komputindo.
- Setiawan, D. B. (2016). PERANCANGAN APLIKASI SISTEM INFORMASI KEPENDUDUKAN DI KECAMATAN GANDOMANAN. *Jurnal Informatika Upgris*, 113-118.
- Setiawan, S., & Suhaeliah, S. (2016, September). RANCANGAN SISTEM INFORMASI DOKUMENTASI KEPENDUDUKAN DI DESA JATIWARINGIN. *Jurnal Sisfotek Global*, 31-39.
- Siahaan, V. (2020). *5 Books in One: Buku Pintar HTML, CSS, JavaScript, jQuery, PHP, dan MySQL*. Balige: Balige Publishing.
- Sumadiono, W. (2018). *Pedoman Umum Organisasi dan Administrasi Rukun Warga Rukun Tetangga*. Yogyakarta: Penerbit Deepublish.
- Suryansah, A., & Habibi, R. (2020). *Aplikasi Prediksi Jumlah Kebutuhan Perusahaan*. Bandung: Kreatif Industri Nusantara.
- Tamami, J. H., Mursityo, Y. T., & Pradana, F. (2019). Pengembangan Sistem Informasi Penjualan Awesam Merchandise Dengan Metode Rational Unified Process. *Jurnal Pengembangan Teknologi Informasi dan Ilmu Komputer*, vol. 3, no. 5, 4809-4817.
- Tambunan, T. S. (2019). *Glosarium Istilah Pemerintahan*. Prenanda Media Group.
- Waluyo, S. (2019). *Menatap Bangsa Hoax Sebuah Catatan Penegakan Good Governance*. Yogyakarta: Deepublish.



This work is licensed under a [Creative Commons Attribution-ShareAlike 4.0 International License](https://creativecommons.org/licenses/by-sa/4.0/)