



EFFECTS OF PRODUCT QUALITY, SERVICE QUALITY, PRICE, FAMILIARITY, REPUTATION, AND APPLICATION QUALITY ON SHOPEE USERS' PURCHASE INTENTION

¹Haliza Rahma Alifia and ²Arif Hartono

¹Student of International Undergraduate Program Department of Management, Faculty of Business and Economics, Universitas Islam Indonesia and ²Senior Lecturer of Department of Management, Faculty of Business and Economics, Universitas Islam Indonesia
18311114@students.uui.ac.id, arif.hartono@uui.ac.id

Abstract

Diterima:
25 Mei 2022
Direvisi:
8 Juni 2022
Disetujui:
14 Juni 2022

This study examines the influence of product quality, service quality, price, familiarity, reputation, and application quality on purchase intention by going through Shopee e-commerce to evoke consumers buying interest. Sampling techniques conducted in this study are non-probability purposive sampling by the criteria of respondents were an active student of UII and have shopped at Shopee. The data were collected by using questionnaire based on Likert scale. The total samples obtained in this study were 217 respondents. The data were then analyzed by using Structural Equation Modeling analysis and calculated by using AMOS software. The final results of this study found that positive and significant influence of the product quality, price, familiarity, reputation, and application quality on purchase intention. However, service quality does not have positive effect on purchase intention.

Keywords: Product Quality, Service Quality, Price, Familiarity, Reputation, Application Quality, Purchase Intention

Abstrak

Penelitian ini menguji pengaruh kualitas produk, kualitas layanan, harga, pengenalan terhadap produk, reputasi, dan kualitas aplikasi pada niat beli melalui e-commerce Shopee untuk membangkitkan minat beli konsumen. Teknik pengambilan sampel yang dilakukan dalam penelitian ini adalah non-probability purposive sampling dengan kriteria responden adalah mahasiswa aktif UII dan pernah berbelanja di Shopee. Pengumpulan data dilakukan dengan menggunakan kuesioner berdasarkan skala Likert. Jumlah sampel yang diperoleh dalam penelitian ini sebanyak 217 responden. Data tersebut kemudian dianalisis dengan menggunakan Structural Equation Modelling dan dihitung dengan menggunakan software AMOS. Hasil akhir penelitian ini menemukan pengaruh positif dan signifikan kualitas produk, harga, pengenalan terhadap produk, reputasi, dan kualitas aplikasi terhadap niat beli. Namun, kualitas layanan tidak berpengaruh positif terhadap niat beli.

Keywords: Kualitas Produk, Kualitas Layanan, Harga, Pengenalan Terhadap Produk, Reputasi, Kualitas Aplikasi, Niat Beli

INTRODUCTION

In this modern era, technology directly and indirectly encourages various system changes, such as the trading systems, the ways of trading, and the marketing systems. In the past, if we bought a product or item, we had to meet the seller first, the seller and the buyer had to meet face to face until both parties reached an agreement, that is usually called as transaction. With the presence of the internet, companies, business people can run their business quickly, easily, and efficiently by creating an online shop or online store. So, communication and marketing will be faster and easier even though they are in different locations. [Tian and Stewart \(2007\)](#) stated that e-commerce or electronic commerce, also known as e-business, refers to the transaction of goods and services through the electronic commerce or internet.

According to [Kemp \(2021\)](#) from WeAreSocial.com it was revealed that in January 2021 internet users worldwide have reached 4,66 billion people, it added up by 316 million (7.3 percent) since this time last year. Report from [Lidwina \(2019\)](#) at Katadata.co.id stated that Indonesia is the largest e-commerce market in Southeast Asia. In 2018, the total transactions in Southeast Asia reached US\$ 23,3 billion. With that amount, 52 percent of transactions came from Indonesia with the worth US\$ 12,2 billion. According to a report from [Rizaty \(2021\)](#) at Databoks.Katadata.co.id, regarding a report by Bank Indonesia, e-commerce transactions in Indonesia are projected to touch Rp. 403 trillion in 2021. This number grew by 51.6% from the previous year which was Rp. 266 trillion. [Hermawan \(2021\)](#) in the report The Map of E-commerce in Indonesia that was published by Iprice.com through Pikiran-Rakyat.com, in Q2 2021, stated that Shopee was ranked first out of 5 e-commerce in Indonesia. Shopee is one of the most popular e-commerce in Indonesia that was first established in 2015 in Singapore by Forrest Li. Shopee in Indonesia brings a new shopping experience that facilitates sellers to sell their product easily and provides buyers with a secure payment process and also integrated logistics arrangements.

Consumers usually have some considerations before making a purchase, such as product quality, price, and reputation of the e-commerce. According to [Dapas et al. \(2019\)](#), purchase intention means cognitive plans or desires for a specific item or brand. Companies need to pay attention to what factors that can influence the purchase intention of their consumers. A number of studies argue that the first factor that influences purchase intention is product quality. According to [Mirabi et al. \(2015\)](#), product quality is a key factor in assessing purchase intention. It is a continuous process of improvement that the continuous changes increase product performance and consequently the satisfaction of consumers' needs. The second factor that influences purchase intention is service quality. Service quality can play a crucial role in a consumer's purchase intention. The customer may want to know about the things such as the procedures of delivery of goods, the e-commerce response to the consumers' request, insurance of goods during delivery, and packaging of goods when they are delivered. Third factor that influences purchase intention is price. Price is an important motivation to attract consumers to make shopping on e-stores, a below market price for products in e-stores have reinforced and abolished the effect of leaving the online shop ([Khan et al., 2015](#)). The fourth factor that influences purchase intention is familiarity. Familiarity is a set of consumer experiences that are associated with a product. Experiences to a product include advertising, information seeking, interaction with sales persons, selection, and decision making ([Adi & Indriani, 2017](#)). The sixth factor that influences purchase intention is reputation. Reputation can be defined as the picture of mind, that is as an image in someone's mind. A good reputation is important for a company because it helps to differentiate with the competitor, and even be a determining factor in whether consumers choose a company over competitors. The last factor that influences purchase intention is application quality. According to [Chen \(2013\)](#), in order to participate with m-commerce, retailers must develop mobile websites that are optimized for various operating systems and their application must be able to sync across devices to convey product information to customers while enabling customers to effectively complete transactions.

RESEARCH METHOD

This study used a quantitative method by collecting questionnaires based on Likert scale. The population is students from Universitas Islam Indonesia that have Shopee account and actively use Shopee. The sample used in this study is a non-probability technique where the sampling technique from the population is found or determined by the researcher itself. The sample selected for this study were students of the Universitas Islam Indonesia in Yogyakarta represented by 217 students from all faculties who have accounts and actively shop at Shopee. Based on this technique, certain criteria for a respondent in this study are based on the number of samples.

- Minimum Sample Size = 5 x total question items = 5 x 31 = 155 respondents
- Maximum Sample Size = 10 x total question items = 10 x 31 = 310 respondents

Table 1 Research Variables

No.	Name of Variable	Function Variable
1	Product Quality	Independent
2	Service Quality	Independent
3	Price	Independent
4	Familiarity	Independent
5	Reputation	Independent
6	Application Quality	Independent
7	Purchase Intention	Dependent

RESULT AND DISCUSSION

The next stage is to make the shape of the research model on AMOS 23 software, the model created in this study is adjusted to the theory and framework of though in previous research. The model in this study is presented in Figure using AMOS 23 software.

Figure. 1 Research Model with AMOS 23

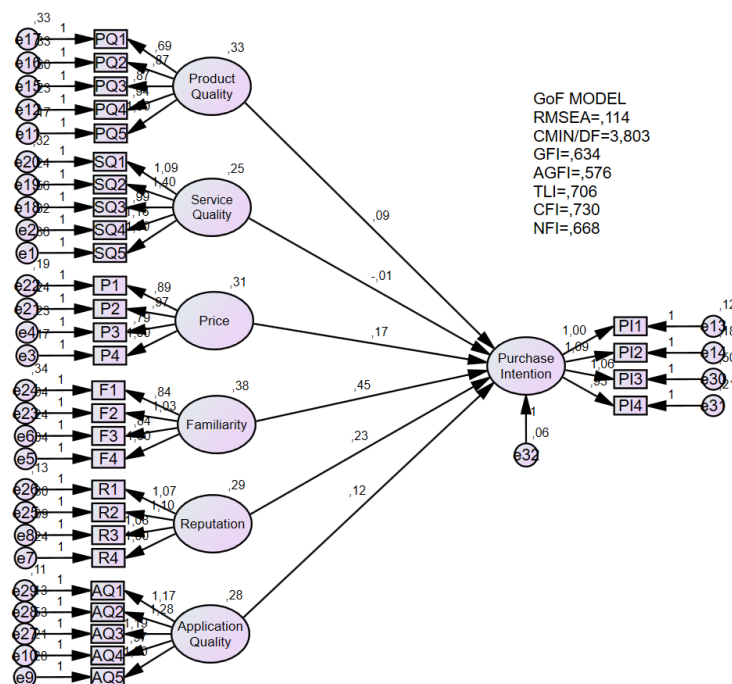
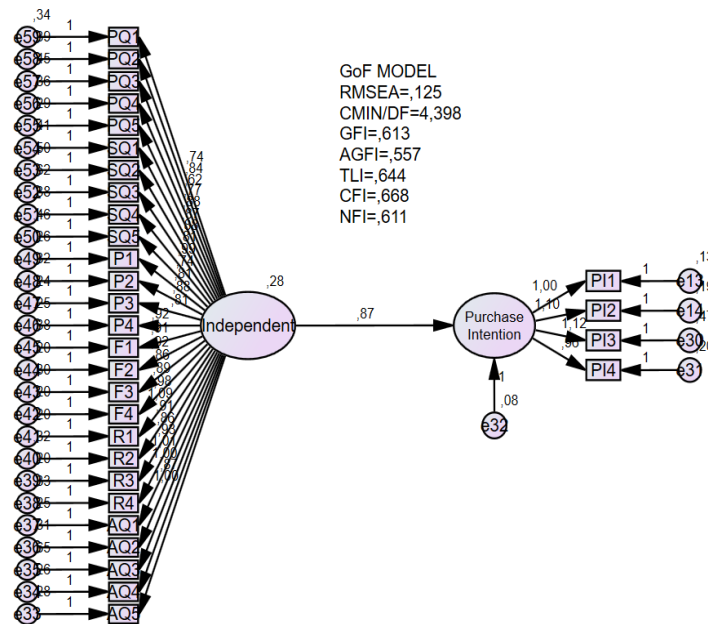

Figure 2 Research Model with AMOS 23



Hypothesis Testing

The findings of hypothesis testing will be reported after the description of the relationship between the variables in this study is identified. The results of the SEM analysis will present the path coefficient values between the variables, and the significance of the hypothesis test results is shown in Table below.

Table 2 Hypothesis Test Results

Connection Between Variable	Estimate	S.E.	C.R.	P	Status
PI ← PQ	0,088	0,045	1,977	0,048	Accepted
PI ← SQ	-0,008	0,051	-0,159	0,874	Rejected
PI ← P	0,166	0,048	3,493	***	Accepted
PI ← F	0,447	0,046	9,741	***	Accepted
PI ← R	0,229	0,049	4,637	***	Accepted
PI ← AQ	0,116	0,047	2,440	0,015	Accepted
PI ← PQ, SQ, P, F, R, AQ	0,874	0,084	10,373	***	Accepted

The results of hypothesis testing of Table shows the relationship between product quality, price, familiarity, reputation, and application quality variables have significant effects on purchase intention. Meanwhile, service quality shows a coefficient value of -0.008 and a p value of 0.874 which is greater than 0.1 (10%). So, it can be concluded that service quality has no significant effect on purchase intention.

Discussion

After the researcher has tested the hypothesis based on the findings of the research, the following discussion can be drawn.

- a) Product Quality has a positive effect on Purchase Intention
Based on the results of data analysis that led to the CFA SEM test, product quality has a positive and significant effect on purchase intention, and the results of H1 were accepted. It means the higher the quality of the product, the higher the user's interest in buying the product. The results of this study are consistent with the previous studies by So et al. (2015) which shows that consumers' perceived quality also has strong influence to increase consumer purchase intention.
- b) Service Quality has a positive effect on Purchase Intention
Based on the results of data analysis that led to the CFA SEM test, service quality has a negative and no significant effect on purchase intention, and the results of H2 are not accepted. Therefore, poor service quality will reduce the company's performance, so that it affects consumer buying interest. The results of this study are not in line with the previous studies by Dapas et al. (2019) which shows that purchase intention is positively influenced by service quality.
- c) Price has a positive effect on Purchase Intention
Based on the results of data analysis that led to the CFA SEM test, price has a positive and significant effect on purchase intention, and the results of H3 were accepted. That is, if the price offered is in accordance with the consumer's expectations, the consumer will buy the product. The results of this study are consistent with the previous studies by Victor et al. (2018) which shows that purchasing a product at the lowest price (showing the highest value) certainly increases the consumer's satisfaction.
- d) Familiarity has a positive effect on Purchase Intention
Based on the results of data analysis that led to the CFA SEM test, familiarity has a positive and significant effect on purchase intention, and the results of H4 were accepted. Therefore, products that are already familiar will be easily recognized by consumers, so that it can also increase consumer buying interest. The results of this study are consistent with the previous studies by Azam and Aldehayyat (2018) which shows that well-known brands provide better memory and decrease levels of perceived risk, which can increase attitude and purchase intention toward brands.
- e) Reputation has a positive effect on Purchase Intention
Based on the results of data analysis that led to the CFA SEM test, reputation has a positive and significant effect on purchase intention, and the results of H5 were accepted. Therefore, a good reputation for the seller will greatly affect the buyer's purchase intention. The results of this study are consistent with the previous studies by Zhen et al. (2021) which shows that consumers may be aware of online reputation sellers. They also revealed that perceived reputation has a high correlation with online purchase intention.
- f) Application Quality has a positive effect on Purchase Intention
Based on the results of data analysis that led to the CFA SEM test, application quality has a positive and significant effect on purchase intention, and the results of H6 were accepted. Therefore, the higher level of application quality, will lead to the increase of purchase intention. The results of this study are consistent with the previous studies by Chen (2013) which shows that the quality of mobile shopping plays an important role in influencing purchase intention and organizational performance.
- g) Product Quality, Service Quality, Price, Familiarity, Reputation, and Application Quality have a positive effect on Purchase Intention
Based on the results of data analysis that led to the CFA SEM test, product quality, service quality, price, familiarity, reputation, and application quality have a positive and significant effect on purchase intention, and the results of H7 are accepted. It shows that good reputation, service quality, varying price, ease of using application, and product quality greatly influence consumer buying intention. The results of this study are consistent with the previous study by Yulisetiarini et al. (2017) which stated that

purchase intentions are significantly affected by price and service quality in online shopping. Sari and Giantari (2020) mentioned that to increase the intention to repurchase it is necessary to pay attention to product quality. Das (2018), the influence of familiarity and trust are especially strong on people's purchase intention. Peng (2020) explained that a good seller reputation has a positive impact on buyer's purchase intention. Lastly, a study from Nursyirwan and Ardaninggar (2020) stated that the higher level of website quality, will lead to higher purchase intention.

CONCLUSION

This study examines effects that can influence purchase intention through product quality, service quality, price, familiarity, reputation, and application quality in E-Commerce. Therefore, the following conclusions can be drawn:

- 1) Through the results of the study analysis, the analysis that have been carried out shows the effect of positive relationship between product quality, price, familiarity, reputation, and application quality on purchase intention. It can be concluded that almost all of the hypotheses that have been formulated can be accepted. From all of the results, service quality has no significant effect on purchase intention.
- 2) From the results, this study is expected to provide insight to Shopee and seller who are members of Shopee in order to develop their business network by paying attention to factors that will have an impact on consumers purchase intention. Understanding the existing factors can help Shopee to be able to plan and implement useful marketing strategies to increase consumers' purchase intention in Shopee.
- 3) Through the study results that were obtained, it was found that familiarity and reputation are a strong factor to influence consumers' purchase intention. Therefore, it is important for Shopee and sellers who are members of Shopee to keep paying attention to their brand image. This can be done by continuing to be consistent in company advertising, educating the sellers regarding the product description, customer service, and ease of use the application. This will increase consumers repurchase intention.

REFERENCES

- Adi, B., & Indriani, F. (2017). Analisis Faktor-Faktor yang Mempengaruhi Minat Beli Produk Private Label. *Diponegoro Journal of Management*, 6(4), 1–12. <http://ejournal-s1.undip.ac.id/index.php/dbr>
- Azam, A., & Aldehayyat, J. (2018). Impact of Informational Social Support and Familiarity on Social Commerce Intention. *European Online Journal of Natural and Social Sciences*, 7(4), 744–757.
- Chen, L. Y. (2013). The Quality of Mobile Shopping System and its Impact on Purchase Intention and Performance. *International Journal of Manging Information Technology (IJMIT)*, 5(2), 23–32.
- Dapas, C. C., Sitorus, T., Purwanto, E., & Ihalauw, J. J. O. I. (2019). The effect of service quality and website quality of zalora.Com on purchase decision as mediated by purchase intention. *Quality - Access to Success*, 20(169), 87–92.
- Das, A. (2018). Role of Familiarity and Trust on the Purchase Behaviour: An Empirical Investigation on Indian E-commerce Industry. *London Journal of Research in Management and Business*, 12(2), 18–50.
- Hermawan, D. (2021). *Duel Sengit 2021, Tokopedia vs Shopee: Mana Jawara Marketplace Sesungguhnya?* Pikiran Rakyat.Com. <https://www.pikiran-rakyat.com/ekonomi/pr-012694512/duel-sengit-2021-tokopedia-vs-shopee-mana-jawara-marketplace-sesungguhnya>

- Kemp, S. (2021). *Digital 2021: The Latest Insights into the "State of Digital."* We Are Social. <https://wearesocial.com/uk/blog/2021/01/digital-2021-the-latest-insights-into-the-state-of-digital/>
- Khan, S. A., Liang, Y., & Shahzad, S. (2015). An Empirical Study of Perceived Factors Affecting Customer Satisfaction to Re-Purchase Intention in Online Stores in China. *Journal of Service Science and Management*, 8(3), 291–305. <https://doi.org/10.4236/jssm.2015.83032>
- Lidwina, A. (2019). *Infografik: Indonesia Pasar Terbesar E-Commerce di Asia Tenggara*. Katadata.Com. <https://katadata.co.id/ariayudhistira/infografik/5e9a503b449cd/infografik-indonesia-pasar-terbesar-e-commerce-di-asia-tenggara>
- Mirabi, V., Akbariyeh, H., & Tahmasebifard, H. (2015). A Study of Factors Affecting on Customers Purchase Intention Case Study: the Agencies of Bono Brand Tile in Tehran. *Journal of Multidisciplinary Engineering Science and Technology (JMEST)*, 2(1), 267–273.
- Nursyirwan, V. I., & Ardanninggar, S. S. (2020). the Factor Analysis That Influence the Student Purchase Intention in Shopee E-Commerce. *Eaj (Economics and Accounting Journal)*, 3(2), 118. <https://doi.org/10.32493/eaj.v3i2.y2020.p118-129>
- Peng, B. (2020). Game Analysis on Online Reputation of Cross-Border E-Commerce. *Fourth Asian B&R Conference on International Business Cooperation (ISBCD 2019)*, 146, 313–316. <https://doi.org/10.2991/aebmr.k.200708.060>
- Rizaty, M. A. (2021). *Transaksi E-Commerce Indonesia Diproyeksikan Capai Rp 403 Triliun pada 2021*. Databoks. <https://dataindonesia.id/digital/detail/transaksi-ecommerce-ditaksir-capai-rp530-triliun-pada-2022>
- Sari, D. A. T. (2020). Role of consumer satisfaction in mediating effect of product quality on repurchase intention. *International Research Journal of Management, IT and Social Sciences*, 7(1), 217–226. <https://doi.org/10.21744/irjmis.v7n1.839>
- Tian, Y., & Stewart, C. (2011). History of E-Commerce. In *Electronic Commerce* (pp. 1–8). IGI Global. <https://doi.org/10.4018/9781599049434.ch001>
- Victor, V., Nathan, R. J., Grabara, J., & Fekete-Farkas, M. (2018). Price tracking behaviour in electronic commerce and the moderating role of fair price perception. *Polish Journal of Management Studies*, 18(2), 375–387. <https://doi.org/10.17512/pjms.2018.18.2.30>
- Yulisetiari, D., Subagio, A., Pramu, H., & Irawan, B. (2017). Customer Repurchase Intention and Satisfaction in Online Shopping. *International Business Management*, 11(1), 215–221. <http://docsdrive.com/pdfs/medwelljournals/ibm/2017/215-221.pdf>
- Zhen, L. Z., Pandey, A., Traiwanmakij, S., Pechinthorn, K., & Smarkjarn, J. (2021). Factors Related To Chinese Customers' Online Purchase Intention: the Case Study of Jingdong. Com Online Shopping'S Customer in China. *International Journal of Economics, Business, and Accounting Research (IJEBAR)*, 5(1), 13–22. <http://jurnal.stie-aas.ac.id/index.php/IJEBAR/article/view/1721>



This work is licensed under a [Creative Commons Attribution-ShareAlike 4.0 International License](https://creativecommons.org/licenses/by-sa/4.0/)